



# Technical Documentation

## ICE-CREAM FREEZERS

Type: **ZL-351**

BYFAL sp. z o.o.  
ul. Perłowa 17  
77-132 Niezabyszewo

More information at: [www.byfal.pl](http://www.byfal.pl)

### Information card

Ice-cream freezer with a direct sales function is intended for display and sale of frozen products.

<b>Model identifier</b>	<b>ZL-351</b>
<b>Device range code</b>	<b>HF7</b>
<b>Net volume [dm<sup>3</sup>]</b>	<b>298</b>
<b>Target temperature [°C]</b>	<b>-14</b>
<b>Duration of the guarantee [month]</b>	<b>24</b>
<b>Minimum ambient temperature / humidity [°C / %]</b>	<b>16 / 80</b>
<b>Maximum ambient temperature / humidity [°C / %]</b>	<b>35 / 75</b>
<b>Annual energy consumption [kWh/a]</b>	<b>693,5</b>
<b>EEI</b>	<b>39,7</b>
<b>Energy efficiency class</b>	<b>D</b>
<b>Additional lighting</b>	<b>Lack</b>
<b>Holes for containers</b>	<b>8</b>



### Dimensions

L	Lw	S	Sw	H	Hw	Packing LxSxH	Net weight	Gross weight
1250	1085	685	473	890	630	1,30 x 0,70 x 0,93	57	69

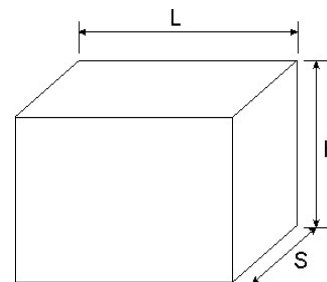
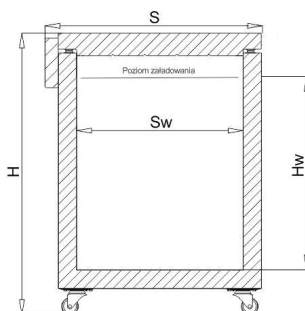
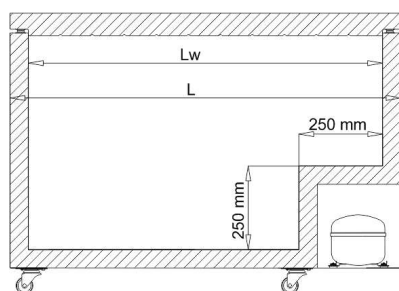

Additional information and instructions can be found on our website: [www.byfal.pl](http://www.byfal.pl)

# Specification

The freezer is built in the shape of a horizontal cabinet. Freezer walls are insulated with polyurethane foam. Outer coat is made of galvanized sheet metal covered with PVC which makes it resistant to corrosion and scratches. Side interior walls of the freezer are made of 99% pure aluminum sheet and the bottom is made of steel sheet covered with a coating that is approved for contact with food. An evaporator is placed under the aluminum sheet. On the front wall under the outer coat there is a condenser. Cover is made with holes for containers. In addition, the refrigeration system includes a compressor and expansion valve in the form of a capillary tube and a filter. An electronic controller is used to control the compressor operation. This allows you to change the setting of the desired cooling temperature and additionally displays the current temperature of the cooling chamber.

## **General product specifications** (UE)2019/2018 zał. VI pkt 1.b.

		Value
Power supply	V/Hz	240 / 50
Current nom./max.	A	0,48/6,1
Installed power	W	114
Holes in the lid		8
Wheels		2+2 <sub>hamulec</sub>
refrigerant	IP	R290
Refrigerant dose	g	45
Defrosting		manual

Parameter	Value	Parameter	Value
Annual energy consumption (kWh/a)	693,5	Standard annual energy consumption (kWh/a)	1748,09
Daily energy consumption (kWh/24h)	1,9	Ambient conditions	Set 2
M	2,0	N	0,009
Temperature coefficient (C)	1,00	Y	309,92
P	1,00		
Climate class factor (CC)	1,04	Target temperature (Tc) (°C)	-18,0

## **Additional information**

The product complies with the following harmonised standards:

PN-EN PN-EN 60335-1:2012/A14:2020-05  
PN-EN 60335-2-24:2010  
PN-EN 55014-1:2017-16  
PN-EN IEC 61000-3-2:2019-04  
PN-EN 61000-3-3:2013-10  
PN-EN 61000-4-2:2011  
PN-EN 61000-4-4:2013-05  
PN-EN 61000-4-5:2014-10  
PN-EN 61000-4-6:2014-04  
PN-EN IEC 61000-4-11:2020-11

## **Model identifier**

Ice-cream freezer **ZL-351/X**

/X – the number of holes in the lid

So when ordering **ZL-351/8** model we get: ice-cream freezer ZL-351 with 8 holes for containers in the lid as in the example photo on page 1 of this information sheet.

## Special precautions

- Please read manual carefully before unpacking and installing. To ensure safety, the instructions must be strictly followed.
- The appliance may be connected to the mains by an authorized person after reading the manual. The connection can be done only to a grounded socket to avoid electric shock.
- It is forbidden to make holes in the housing of the device. It may cause release of flammable refrigerant.
- Air vents in the housing of the appliance must not be obstructed.
- The freezer should be placed in such a way that the plug is accessible.
- You can not obstruct the front wall of the freezer or stick on it thick insulating stickers.
- Make sure that the appliance is not standing on the power supply cable.
- Install the appliance in a dry room with the area of not less than 4m<sup>2</sup>, above the ground level. Avoid locations near a source of heat or in direct sunlight. The temperature in the room must not be lower than 16°C.
- Do not leave the device on a slope without the braked wheels.
- Installation and maintenance of the appliance may not be done by persons ( including children ) with reduced physical, sensory or mental capabilities.
- Do not store glass containers with liquids, electrical appliances or other objects with sharp edges inside the freezer.
- In the case of freezer failure or damage the power cable insulation, repairs may be made only by a person authorized to repair this type of appliance.
- **Attention! Danger of explosion or fire.**

**The installation contains flammable gas. Perforation of the internal or external walls of the housing can cause escape of the flammable refrigerant .**

**If such a case occurs, the lid should not be closed. Do not use near open flames or sparking devices. Disconnect the appliance from the mains power supply, remove it outside and only there you can take out the products.**

## Energy efficiency class:

Determination of the energy efficiency class in accordance with the Commission Delegated Regulation (EU) 2019/2018 of 11 March 2019r.

### Ad.1 Ambient conditions.

Dry bulb temperature [°C]	Relative humidity [%]	Dew point [°C]	Water vapour mass in dry air, [g/kg]
30	55	20,0	14,8

### Ad.2 Determination of the EEI:

$$AE = 365 \times E_{\text{daily}} = 365 \times 1,9 = 693,5$$

$$Y = V_{\text{netto}} \times ((12-T_c)/30) \times CC = 298 \times 1 \times 1,04 = 309,92$$

$$SAE = 365 \times P \times (M + N \times Y) \times C = 365 \times 1 \times (2,0 + 0,009 \times 309,92) \times 1 = 1748,09$$

$$EEI = AE/SAE = 693,5 / 1748,09 = 0,397 \times 100 = 39,7\%$$

$E_{\text{daily}}$  - Determined in a laboratory test in accordance with ISO 23953-2:2016-04

Energy efficiency classes	Energy efficiency index
A	$EEI < 10$
B	$10 \leq EEI < 20$
C	$20 \leq EEI < 35$
D	$35 \leq EEI < 50$
E	$50 \leq EEI < 65$
F	$65 \leq EEI < 80$
G	$EEI \geq 80$

